

**HUSSMANN®**

ESBD

*IMPACT ELITE*

*Curved Glass, Blower Coil Service Case for Deli*



# ESBD - Curved Glass Service Case for Deli With Blower Coil

**HUSSMANN®**  
**Impact Elite**

Standard Lengths: 4', 6', 8', 12'

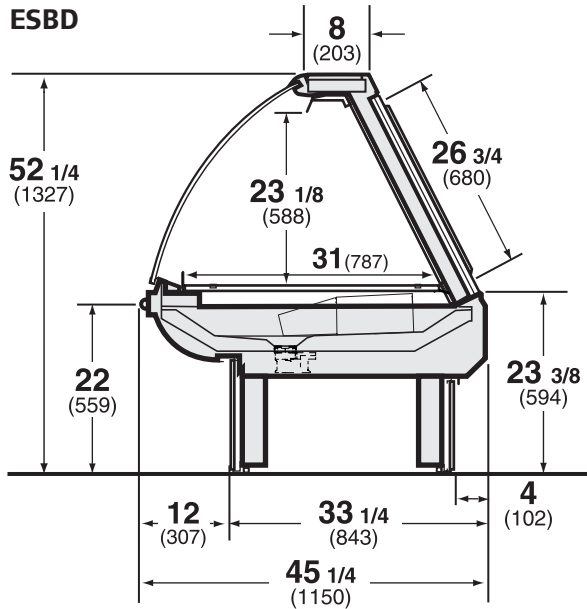

Note: Please use Hussmann's technical data sheets to get precise dimensions for all store layout purposes.

### ESBD Plan Views

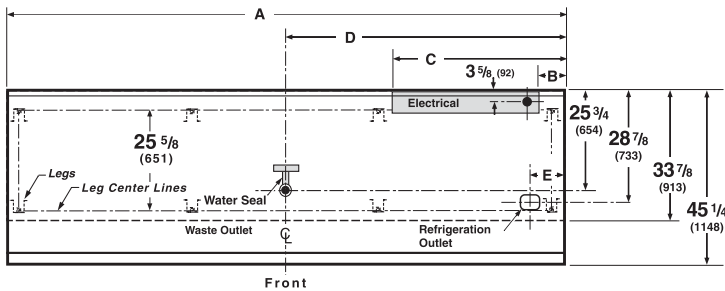

Dimension	A	B	C	D	E
4 foot	48 1/4 (1226)	6 5/8 (170)	45 1/8 (1147)	24 (610)	9 3/8 (238)
6 foot	72 1/4 (1835)	6 5/8 (170)	32 5/8 (830)	24 (610)	9 3/8 (238)
8 foot	96 3/8 (2448)	6 5/8 (170)	45 1/8 (1147)	24 (610)	9 3/8 (238)
12 foot	144 1/2 (3670)	6 5/8 (170)	45 1/8 (1147)	72 1/4 (1834)	9 3/8 (238)

Note: Overall case length without ends or partitions

### Merchandising Excellence

The ESBD delivers high impact merchandising opportunities for your specialty operations. These aesthetically advanced, high performance curved glass models are ideal for high profit, service deli products. Large rear doors and lift up front glass make these cases extremely easy to use. Many flexible options are also available.

### Elite Styling

Dramatic appearance with uncompromising attention to detail is a hallmark of Impact Elite. The ESBD provides a stylish, attention-getting format to help you achieve maximum sales with your creative deli displays. These cases can be combined with companion models to create spectacular line-ups that make your specialty merchandising come to life.

### Proven Impact Performance

The advanced refrigeration technology of Hussmann Impact is now available in the Impact Elite line, giving you better product temperatures, longer shelf life, lower energy costs, fewer refrigerant leaks and easier cleaning and maintenance. Get ultimate styling and ultimate performance with Impact Elite.

*At last, advanced styling plus world-class performance and energy efficiency... that's Impact Elite.*

NOTE: These merchandisers are designed for use in stores when temperature and humidity do not exceed 75° F and 55% R.H.

NOTE: We reserve the right to change or revise specifications and product design in connection with any feature of our products. Such changes do not entitle the buyer to corresponding changes, improvements, additions, or replacements for equipment previously sold or shipped.

**IR Ingersoll Rand**  
Climate Control Technologies

**Hussmann Corporation**  
12999 St. Charles Rock Rd.  
Bridgeton, MO 63044-2483  
(314) 291-2000  
(314) 298-4756 Fax

Web Site: [www.hussmann.com](http://www.hussmann.com)  
E-mail: [hussmann-marketing@irco.com](mailto:hussmann-marketing@irco.com)