

Single Deck Fresh and Frozen
Meat Display



Single Deck Meat Merchandisers

M1 - Single Deck Meat

M1E - Single Deck Meat With High Efficiency Coil

M1G - Single Deck Meat With Glass Front

M1GE - Single Deck Meat With Glass Front And High Efficiency Coil

M1LGE - Single Deck Frozen Meat With Glass And High Efficiency Coil

Available in 8' and 12' Lengths.

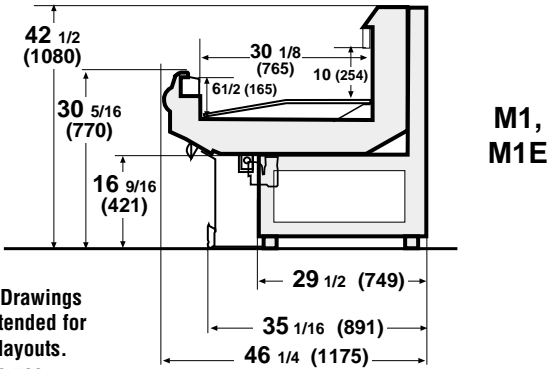

**M1,
M1E**

Note: Drawings not intended for store layouts. Please use Hussmann's Merchandiser Data Book to get precise dimensions for all store layout purposes.

**M1G,
M1GE
M1LGE**

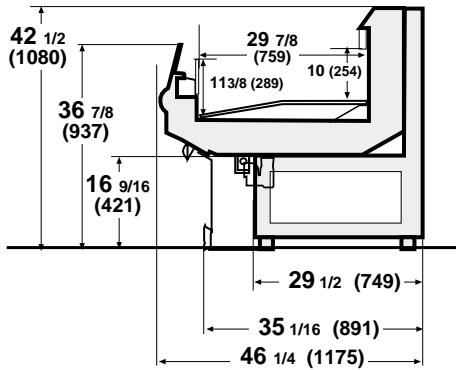

M1 - 8' - 12' Plan

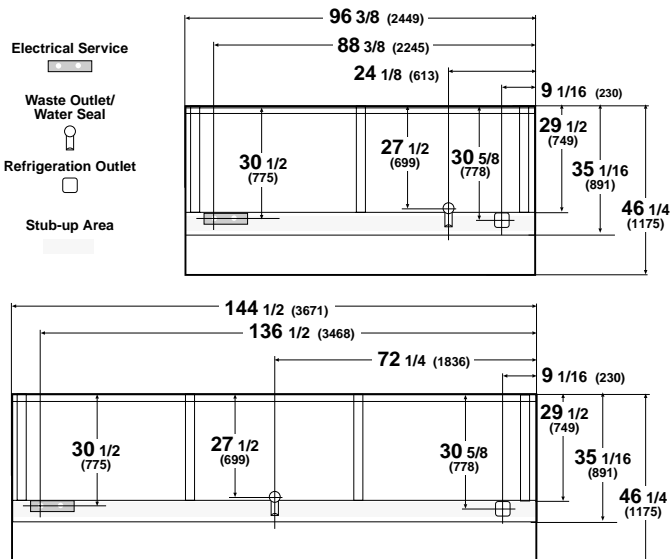

Modular Design

Breakthrough modular design with each 4 foot module containing separate coil, fan plenums and back panels for superior energy efficiency, refrigeration performance and sanitation.

Refrigerant Savings

50% to 60% less refrigerant needed in each merchandiser. Far fewer solder joints to prevent leaks.

Refrigeration Performance Benefits

Dramatic performance improvements include colder more uniform product temperatures throughout display area, even during defrost.

Off-Time Defrost Advantage With Modular Coils

Off-time defrost highly recommended with Impact modular coils. It provides quick, thorough defrost at lowest cost with excellent product temperature stability. (Frozen Meat Uses Electric Defrost)

Easier Sanitation

One piece, high impact polystyrene "bathtub" bottom with seamless, radiused corners. Rear mounted coils. Swing up fan plenum provides full access to case bottom. "No tools" lift out interior panels/components.

Solid Structure

Highly durable bumper system. Heavy duty base.

NOTE: These merchandisers are designed for use in stores when temperature and humidity do not exceed 75°F and 55% R.H.

NOTE: (We reserve the right to change or revise specifications and product design in connection with any feature of our products. Such changes do not entitle the buyer to corresponding changes, improvements, additions, or replacements for equipment previously sold or shipped.)

©2000, 2002 Hussmann Corporation

Hussmann Web Site: <http://www.hussmann.com>
E-mail: marketing@hussmann.com



Hussmann Corporation
12999 St. Charles Rock Rd.
Bridgeton, MO 63044-2483
(314) 291-2000
Fax: (314) 298-4756

An **IR** Ingersoll Rand business