

Four Deck Produce Display

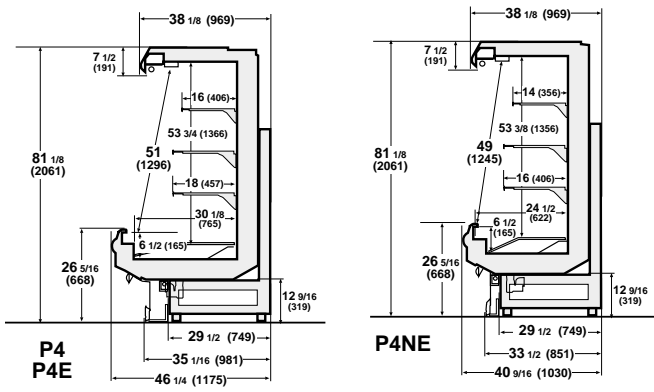

Four Deck Produce Merchandisers

P4 - Refrigerated Four Deck Produce
P4E - Four Deck Produce With High Efficiency Option
Available in 8' and 12' Lengths.



Note: Drawings not intended for store layouts. Please use Husmann's Merchandiser Data Book to get precise dimensions for all store layout purposes.

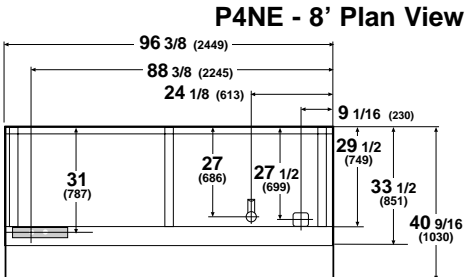
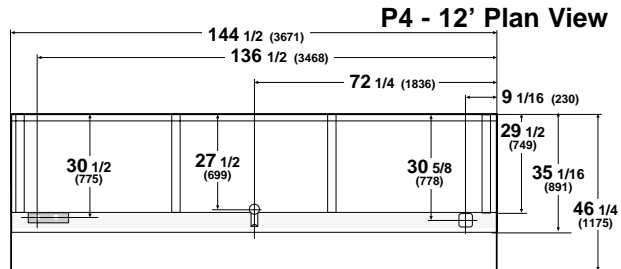
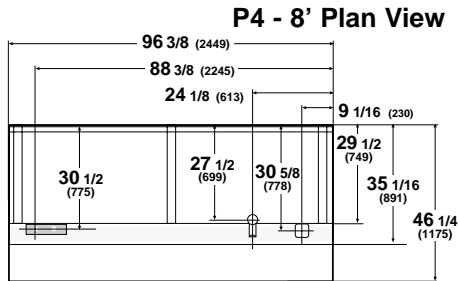

- Electrical Service
- Waste Outlet/ Water Seal
- Refrigeration Outlet
- Stub-up Area

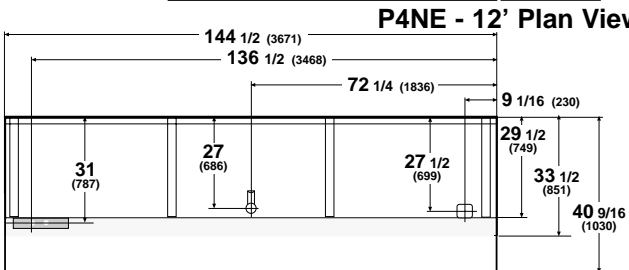

Smaller Refrigerant Charge

50% to 60% less refrigerant needed in Impact merchandisers compared with previous product lines.

Substantial Energy Reductions

Energy use is reduced through modular coil, air flow and lighting features. Brighter, more efficient T-8 lights standard. High efficiency model (P4E) further reduces energy use.

High Impact Merchandising

High profile P4 creates dramatic, highly flexible display possibilities with wide assortment of product types.

Modular Design

Breakthrough modular design with each 4 foot module containing separate coil, fan plenum and back panels.

Refrigeration Performance Improvements

Colder product temperatures with minimal variation throughout display area, even during defrost.

Excellent Sanitation Features

One piece, high impact polystyrene "bathtub" bottom with seamless, radiused corners is leak-proof, rust-proof and much easier to clean. Rear mounted coils and hinged modular fan plenums improve sanitation access. "No tools" removal of shelf supports, flue and back panels.

Durability Plus Quick Installation

Shock absorbing dual bumpers. Full length internal and external support frames. Heavy duty base and skids. Improved access to joining bolt holes. No TEV adjustment required.

NOTE: These merchandisers are designed for use in stores when temperature and humidity do not exceed 75°F and 55% R.H.

NOTE: (We reserve the right to change or revise specifications and product design in connection with any feature of our products. Such changes do not entitle the buyer to corresponding changes, improvements, additions, or replacements for equipment previously sold or shipped.)

©2000, 2002 Husmann Corporation

Husmann Web Site: www.husmann.com
E-mail: marketing@husmann.com



Husmann Corporation
12999 St. Charles Rock Rd.
Bridgeton, MO 63044-2483
(314) 291-2000
Fax: (314) 298-4756